

VORTEX GENERATORS - MAINTENANCE PRACTICES

1. General

- A. The Model 208B airplane with the TKS cargo pod or fairing installation, has vortex generators (VG's) installed on the leading edge surface of each wing to improve air flow on control surfaces. There are equally spaced VG's on the upper surface of each wing. This section gives maintenance practices for the wing VG's that includes removal and installation.
- (1) Model 208B airplane with the TKS cargo pod installation has 10 VG's installed equally spaced at 27 inches on each wing. There are no VG's installed on or behind of the landing light assembly.
 - (2) Model 208B airplane with the TKS fairing installation has 37 VG's installed equally spaced at 6 inches on each wing. There are no VG's installed on or behind of the landing light assembly. For airplanes that have radar installed there are no VG's installed behind the radar fairing.

2. Tools and Equipment

- A. For a list of tools and equipment, refer to Wings - General.

3. Vortex Generator Removal/Installation

NOTE: Removal and installation of the VG's is typical for the left and right wing leading edges.

NOTE: It is recommended that you replace all used VGs with new VGs when you complete this VG removal/installation procedure.

- A. Remove the Vortex Generator (Refer to Figure 201).

WARNING: Cement and solvent vapors are toxic and extremely flammable. Use only in a well ventilated area away from sparks or vapors. Excess exposure could cause injury or death. If dizziness or nausea occur, obtain fresh air immediately. Avoid contact with skin or eyes. Use solvent resistant gloves to minimize skin exposure. Use safety glasses to minimize chance of eye contact. If eye contact occurs, flush eyes with water for 15 minutes and see a physician. If skin contact occurs, wash thoroughly with soap and water. If swallowed, do not induce vomiting. See a physician immediately.

WARNING: Verify aircraft is electrically grounded to prevent static sparks which could ignite solvent vapors.

- (1) Use Methyl n-Propyl Ketone (MPK) solvent cleaning compound to lift the edge of the VG, and remove the VG.
- (2) When a sufficient piece of the VG is lifted, use hands or pliers and more removal solvent to pull the VG off the wing surface.
- (3) Discard the used VG.
- (4) Clean the remaining adhesive from the wing surface with Methyl n-Propyl Ketone (MPK) solvent cleaning compound.
 - (a) Use a cloth in one hand wetted with the MPK solvent and a clean dry cloth in the other hand.
 - (b) Wipe the solvent immediately from the cleaned surface before it evaporates.

NOTE: Cloth should be folded each time surfaced is wiped to present a clean area and avoid redepositing of grease.

- (5) Visually inspect the wing for corrosion where the VG was installed.

(a) If you find corrosion it must be repaired. Refer to the Model 208, Structural Repair Manual, Chapter 51, Corrosion.

- B. Install the Vortex Generator (Cargo Pod Installation) (Refer to Figure 201).

- (1) Find the location on the wing where the VG is to be installed.

NOTE: The VG (with the paper backing intact) can be used to outline the area to be prepared.

NOTE: The vortex generators are installed 27.00 inches center to center, parallel to the wing station, with the peak pointing aft.

- (2) To locate the alignment for the points of the VG's do the steps that follow:

- (a) At WS 39.00 measure from the top of the porous panel to a point on the upper wing surface 5.75 inches (146.05 mm) Along Contour (A.C.).
- (b) At WS 304.00 measure from the top of the porous panel to a point on the upper wing surface 5.31 inches (134.87 mm) Along Contour (A.C.).
- (c) Snap a line between the two points.

(d) Put the peak of each VG at the line, parallel to the wing station.

- (3) Apply masking tape to the area around the installation surface on the boot. Leave approximately a 0.15 inch, (3.81 mm) distance between the tape and the edges of the VG.

CAUTION: For best results, do not install if temperature is below 50° F (10° C). The vortex generators are temperature sensitive and will bond best when then temperature is 50° F (10° C) or above.

- (4) Apply EC-1300L adhesive to the wing surface where the VG will be installed, and to the VG bond surface. Refer to Chapter 20, Adhesive and Solvent Bonding - Maintenance Practices.
- (5) Put the VG in the correct position on the wing surface.
- (6) Mask the VG before painting or sealing.
- (7) Use the adhesive and apply a fillet seal around the base of the vortex generator.
- (8) Apply primer and paint to agree with the exterior finish of the airplane. Refer to Chapter 20, Interior and Exterior Finish - Cleaning/Painting.

C. Install the Model 208B Vortex Generator (Fairing Installation) (Refer to Figure 202).

- (1) Find the location on the wing where the VG is to be installed.

NOTE: The VG (with the paper backing intact) can be used to outline the area to be prepared.

NOTE: The vortex generators are installed 6.00 inches inboard edge to inboard edge, parallel to the wing station, with the peak pointing aft.

- (2) To locate the alignment for the points of the VG's do the steps that follow:

- (a) From WS 35.00 measure 7 inches to the front inboard corner of the first VG.
- (b) At the wing root measure WS 35.00 measure from the top of the porous panel to a point on the upper wing surface 0.5 inches (12.7 mm) Along Contour (A.C.).
- (c) At the wing tip measure from the top of the porous panel to a point on the upper wing surface 0.5 inches (12.7 mm) Along Contour (A.C.).
- (d) Snap a line between the two points.
- (e) Put the forward edge of each VG at the line, parallel to the wing station.

- (3) Apply masking tape to the area around the installation surface on the wing. Leave approximately a 0.15 inch, (3.81 mm) distance between the tape and the edges of the VG.

CAUTION: For best results, do not install if temperature is below 50° F (10° C). The vortex generators are temperature sensitive and will bond best when then temperature is 50° F (10° C) or above.

- (4) Apply EC-1300L adhesive to the wing surface where the VG will be installed, and to the VG bond surface. Refer to Chapter 20, Adhesive and Solvent Bonding - Maintenance Practices.
- (5) Put the VG in the correct position on the wing surface.
- (6) Mask the VG before painting or sealing.
- (7) Use the adhesive and apply a fillet seal around the base of the vortex generator.
- (8) Apply primer and paint to agree with the exterior finish of the airplane. Refer to Chapter 20, Interior and Exterior Finish - Cleaning/Painting.

Figure 201 : Sheet 1 : TKS Cargo Pod Vortex Generator Installation

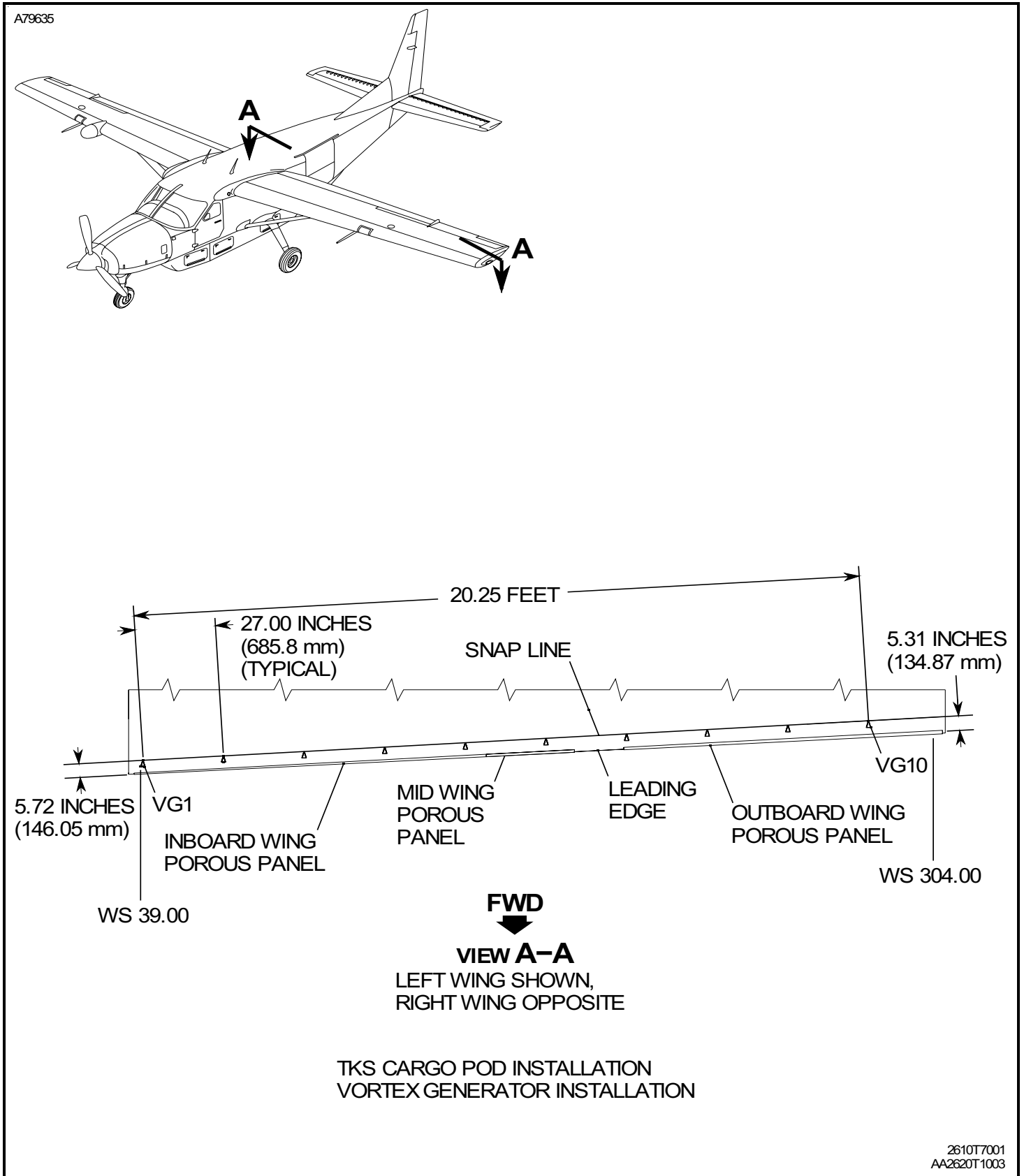
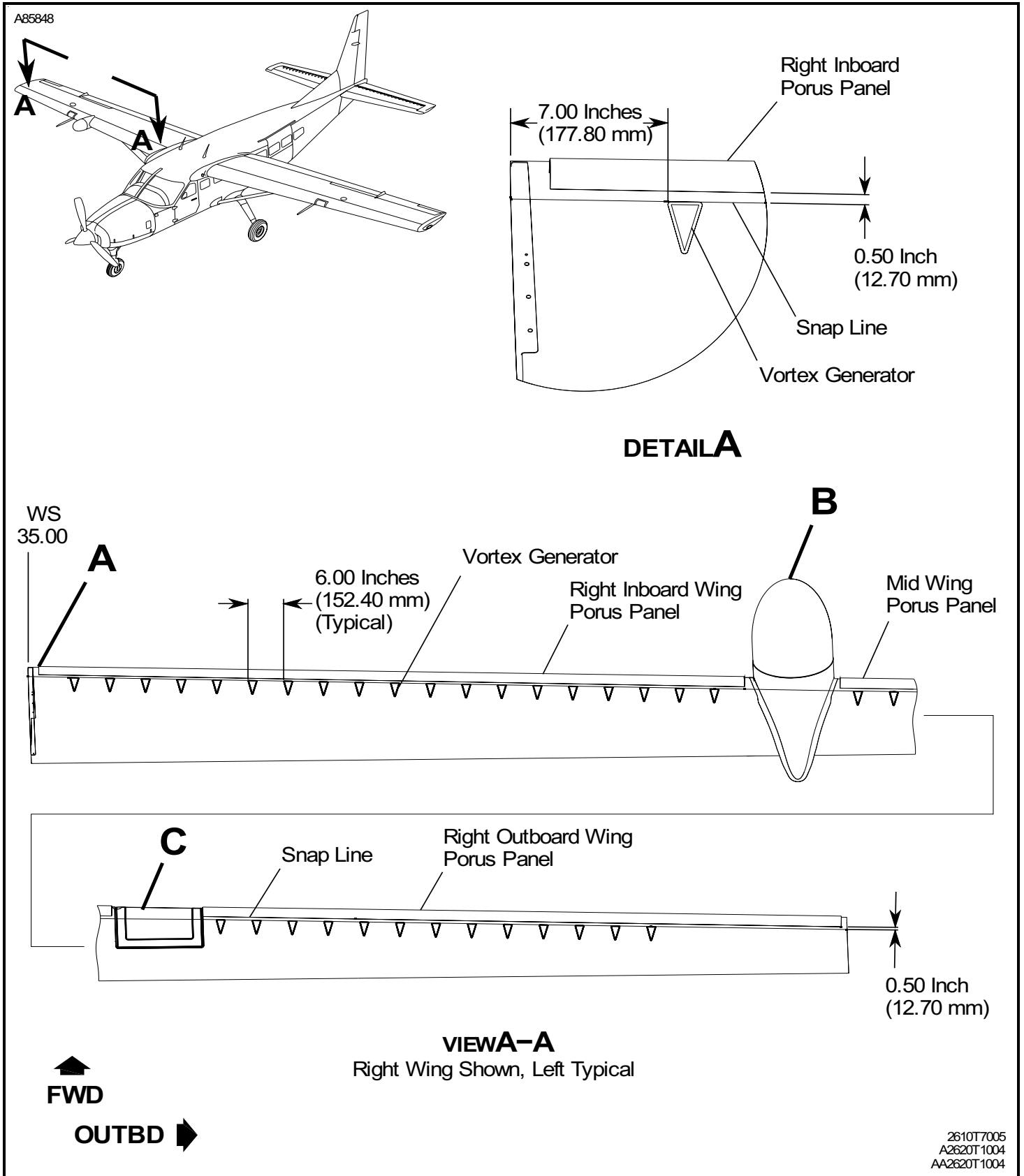

Figure 202 : Sheet 1 : TKS Fairing Vortex Generator Installation



2610T7005
 A2620T1004
 AA2620T1004

Figure 202 : Sheet 2 : TKS Fairing Vortex Generator Installation

A85849

